

SL-PLC SUPER SERIES, LOGIC VALVE

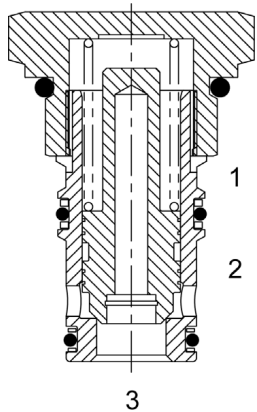

DESCRIPTION

16 size, 1 5/16-12 thread, "Super" series, logic valve.

OPERATION

The SL-PLC with an orifice between ports (3) and (1) maintains a constant flow rate from (3) regardless of load pressure changes in the system upstream of (3), or in the bypass leg at (2) as long as pressure at (2) is less than (1). Used for basic bidirectional blocking applications.

FEATURES

- Hardened parts for long life.
- Industry common cavity.



For metering see SL-PCA or SL-PCB.

HYDRAULIC SYMBOL

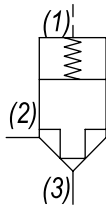

PERFORMANCE

Actual Test Data (Cartridge Only)

VALVE SPECIFICATIONS

Nominal Flow	40 GPM (151 LPM)
Rated Operating Pressure	3500 PSI (241 bar)
Viscosity Range	36 to 3000 SSU (3 to 647 cSt)
Filtration	ISO 18/16/13
Media Operating Temp. Range	-40° to 250°F (-40° to 120°C)
Weight	.65 lbs (.29 kg)
Operating Fluid Media	General Purpose Hydraulic Fluid
Cartridge Torque Requirements	90 ft-lbs (122 Nm)
Cavity	SUPER 3WS
Cavity Form Tool (Finishing)	40500021
Seal Kit	21191409
Seat Ratio	Area of the pilot is 2 times the area of the seat at Port (3)

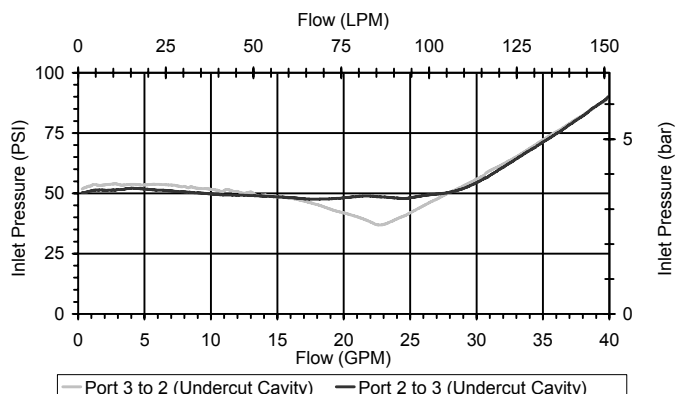
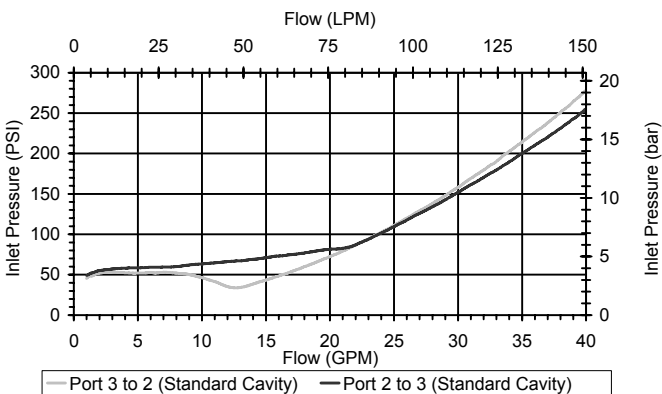

WARNING: the specifications/application data shown in our catalogs and data sheets are intended only as a general guide for the product described (herein). Any specific application should not be undertaken without independent study, evaluation, and testing for suitability.

Via Malavolti, 36 - 41122 Modena - ITALY - Phone +39 (059) 254895 - Fax +39 (059) 253512 - mail: tecnord@tecnord.com - www.tecnord.com

DIMENSIONS

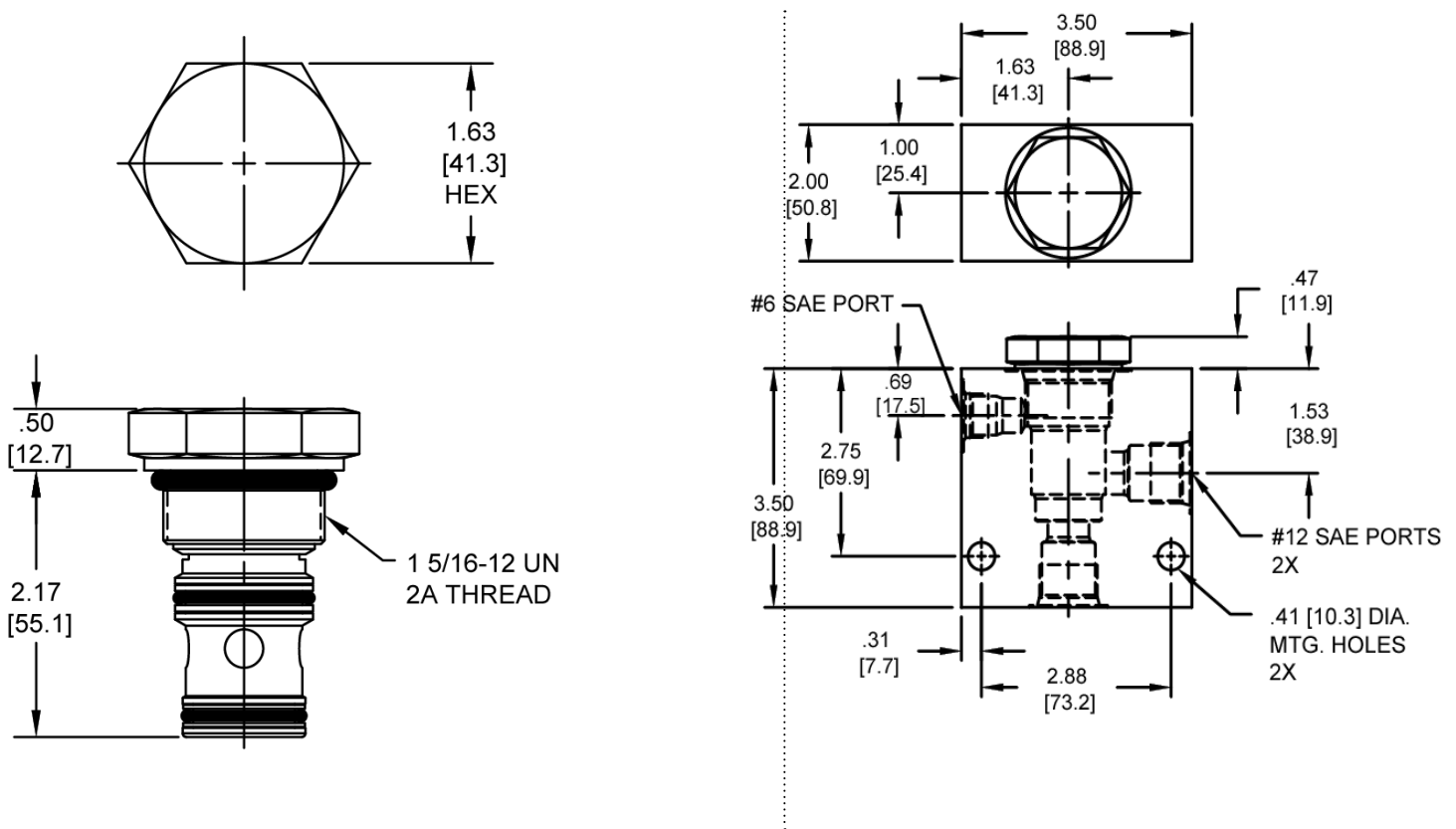

Body Weight: 1.89 lbs (.86 kg)

ORDERING INFORMATION

<p>SL-PLC - - -</p> <p>OPTIONS</p> <p>Buna, Pilot to Close 0P</p> <p>Viton, Pilot to Close VP</p> <p>Buna, Pilot to Close w/seals 0B</p> <p>Viton, Pilot to Close w/seals VB</p>	<p>BODIES</p> <p>Blank Without Body</p> <p>S #12 SAE Ports</p>	<p>PRESSURE SETTING</p> <p>0020 20 PSI</p> <p>0050 50 PSI</p> <p>0100 100 PSI</p> <p>0150 150 PSI</p>
--	--	--

W 50/ 2022

WARNING: the specifications/application data shown in our catalogs and data sheets are intended only as a general guide for the product described (herein). Any specific application should not be undertaken without independent study, evaluation, and testing for suitability.