

**SL-PCE ADJUSTABLE PRESSURE COMPENSATING REGULATOR VALVE**

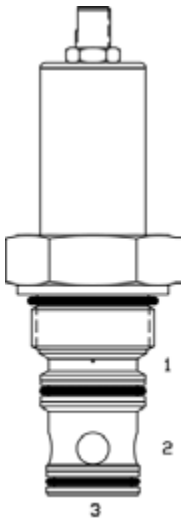

**DESCRIPTION**

16 size, 1 5/16-12 thread, "Super" series, pressure compensating regulator valve.

**OPERATION**

The SL-PCE with an external orifice in parallel with ports (3) and (1) maintains a constant flow rate across the external orifice, regardless of load pressure changes in the system upstream of (3), or in the bypass leg at (2) as long as pressure at (2) is less than (1). The valve's spool maintains a constant differential pressure across the external orifice, thereby regulating the hydraulic flow rate across the external orifice (see options table for pressure ranges). When used with an orifice as described above, it functions as a priority type regulator, delivering pump flow first to the external orifice, then bypassing excess to (2). All ports may be fully pressurized.

**FEATURES**

- Hardened parts for long life.
- Industry common cavity.

**HYDRAULIC SYMBOL**

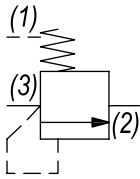

*Can be used as an adjustable logic element. Great as an adjustable pressure setting regulation device in brake, transmission & cooling systems. Because the spring chamber is separately drained, the outlet flow can be used for lower pressure functions. For fixed version see SL-PCA-oP. For higher spring differential pressure ranges consult factory.*

**PERFORMANCE**

Actual Test Data (Cartridge Only)

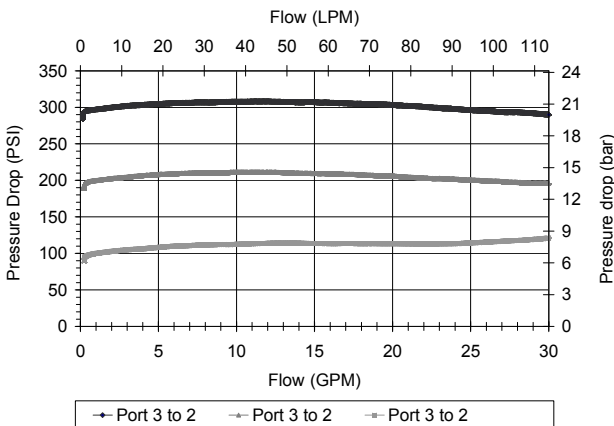

**VALVE SPECIFICATIONS**

Nominal Flow	40 GPM (151 LPM)
Rated Operating Pressure	3500 PSI (241 bar)
Seat Ratio	Area of Pilot is equal to the area at Port (3)
Viscosity Range	36 to 3000 SSU (3 to 647 cSt)
Filtration	ISO 18/16/13
Media Operating Temp. Range	-40° to 250°F (-40° to 120°C)
Weight	1.15 lbs (.52 kg)
Operating Fluid Media	General Purpose Hydraulic Fluid
Cartridge Torque Requirements	90 ft-lbs (122 Nm)
Cavity	SUPER 3WS
Cavity Form Tool (Finishing)	40500021
Seal Kit	21191406

**WARNING:** the specifications/application data shown in our catalogs and data sheets are intended only as a general guide for the product described (herein). Any specific application should not be undertaken without independent study, evaluation, and testing for suitability.

Via Malavolti, 36 - 41122 Modena - ITALY - Phone +39 (059) 254895 - Fax +39 (059) 253512 - mail: [tecnord@tecnord.com](mailto:tecnord@tecnord.com) - [www.tecnord.com](http://www.tecnord.com)

DIMENSIONS

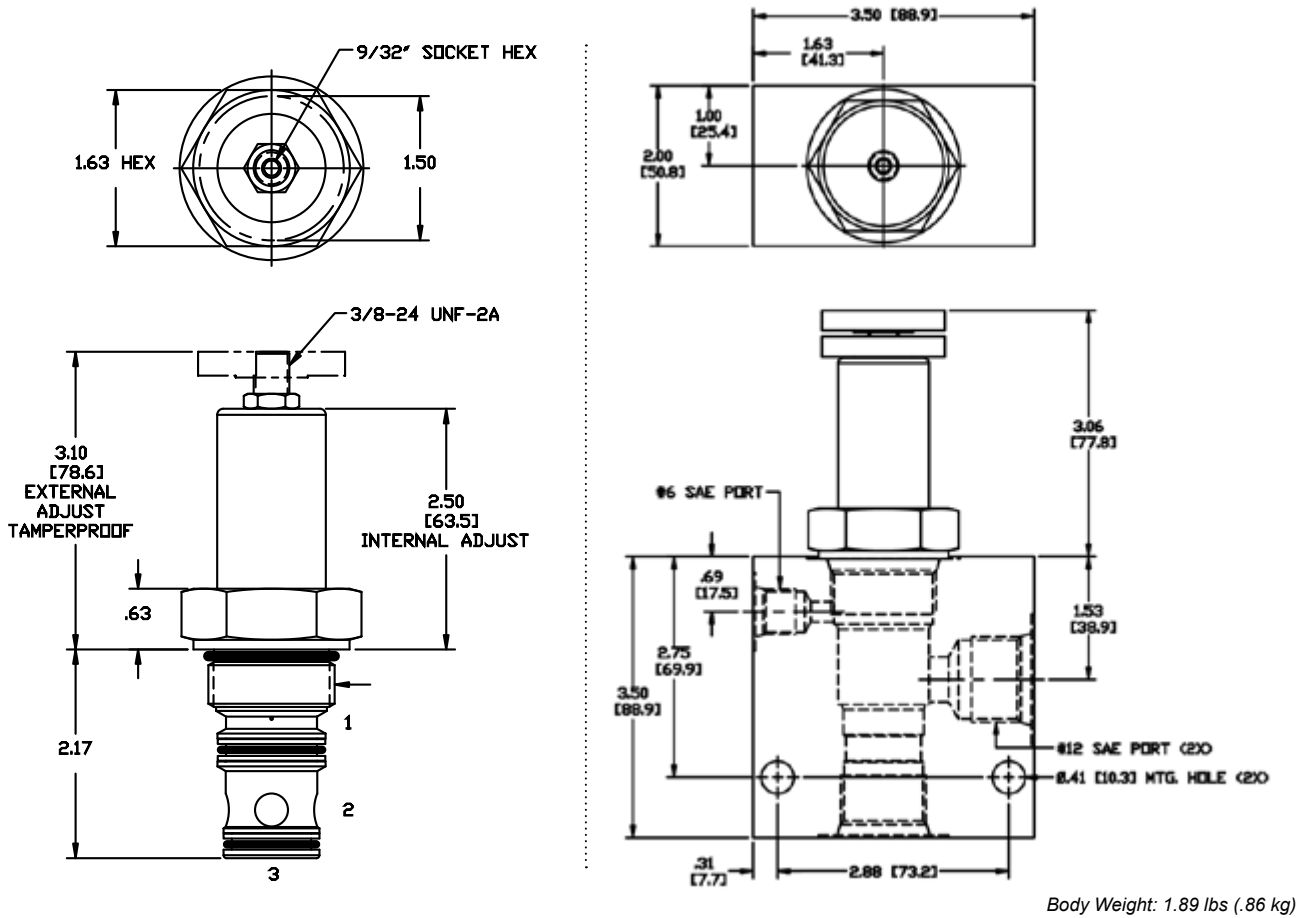

ORDERING INFORMATION

<p><b>SL-PCE</b> - - -</p> <p><b>OPTIONS</b></p> <p>Buna Standard <b>00</b></p> <p>Viton Standard <b>V0</b></p> <p>Buna, Knob <b>0K</b></p> <p>Viton, Knob <b>VK</b></p> <p>Buna, Internal Adjust <b>0I</b></p> <p>Viton, Internal Adjust <b>VI</b></p> <p>Buna, Tamper Proof <b>0T</b></p> <p>Viton, Tamper Proof <b>VT</b></p>	<p><b>BODIES</b></p> <p>Blank Without Body</p> <p><b>S</b> #12 SAE Ports</p>	<p><b>PRESSURE RANGE/SETTING</b></p> <p><b>0300</b> 50 - 300 PSI</p> <p><b>Tamper Proof</b> Fill in 4 Digit Pressure Setting Example: 0200 - 200 PSI</p>
--	--	--