

HB-S2K PILOTED OPERATED POPPET, 2 WAY DOUBLE LOCK NORMALLY OPEN

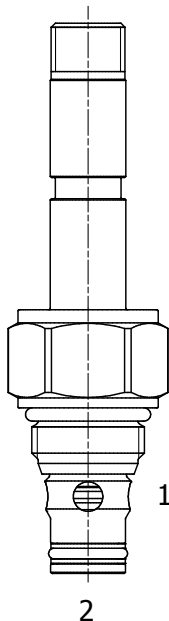

DESCRIPTION

8 size, 3/4-16 thread, "Power" series, solenoid operated, 2 way double lock normally open, pilot operated bidirectional poppet valve.

OPERATION

When de-energized the HB-S2K allows flow from (1) to (2) or from (2) to (1). When energized the valve blocks flow from (1) to (2) and block flow from (2) to (1).

FEATURES

- Hardened parts for long life.
- Efficient wet-armature construction.
- Cartridges are voltage interchangeable.
- Manual override option.
- Industry common cavity.
- Unitized, molded coil design.
- Continuous duty rated solenoid.
- Optional coil voltages and terminations.

HYDRAULIC SYMBOL

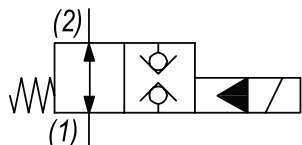

Zinc Nickel plating on all exposed surfaces (>500hours corrosion resistance).

PERFORMANCE

Actual Test Data (Cartridge Only)

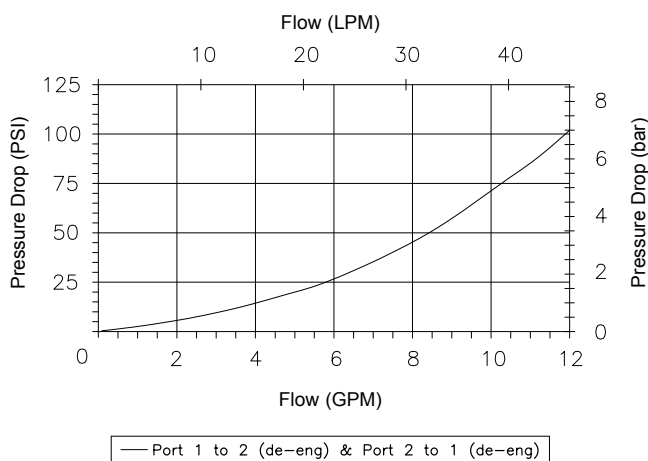

VALVE SPECIFICATIONS

Nominal Flow	12 GPM (45 LPM)
Rated Operating Pressure	5000 PSI (345 bar)
Typical Internal Leakage (150 SSU)	0-5 drops/min at 5000 PSI (345 bar)
Viscosity Range	36 to 3000 SSU (3 to 647 cSt)
Filtration	ISO 18/16/13
Media Operating Temp. Range	-40° to 210°F (-40° to 100°C) BUNA seals -4° to 250°F (-20° to 120°C) VITON seals
Weight	.29 lbs (.13 kg)
Operating Fluid Media	General Purpose Hydraulic Fluid
Cartridge Torque Requirements	30-35 ft-lbs (41-47 Nm)
Coil Nut Torque Requirements	3-4.5 ft-lbs (4-6 Nm)
Cavity	POWER 2W
Cavity Tools Kit	40500005
Seal Kit	21191102

WARNING: the specifications/application data shown in our catalogs and data sheets are intended only as a general guide for the product described (herein). Any specific application should not be undertaken without independent study, evaluation, and testing for suitability.

DIMENSIONS

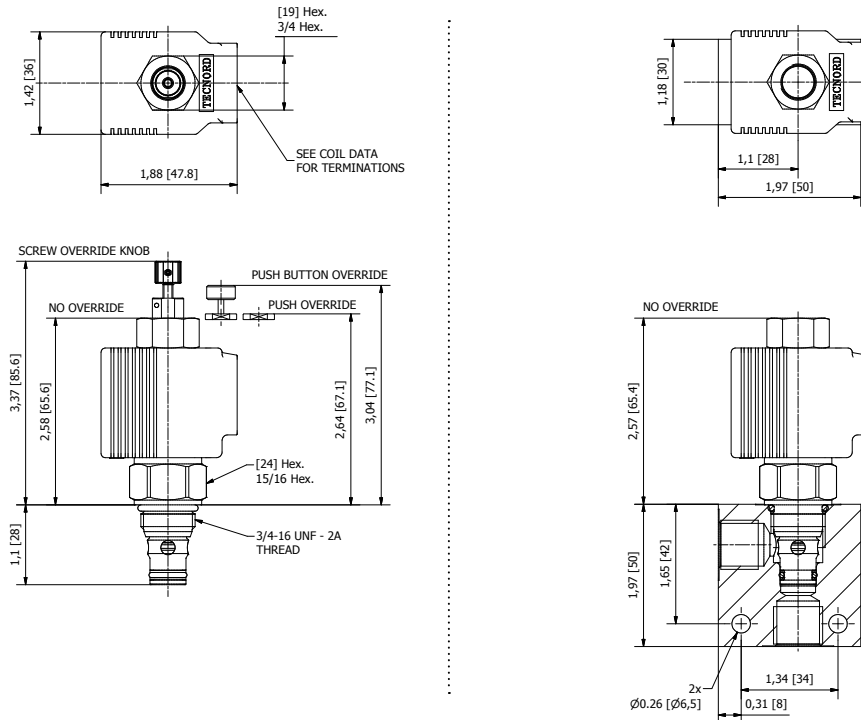

ORDERING INFORMATION

Approximate Coil Weight: .42 lbs (.19 kg)

HB-S2K - - - -

OPTIONS

- Buna Standard **00**
- Viton Standard **V0**
- Buna, Push Pin, Override **0P**
- Viton, Push Pin, Override **VP**
- Buna, Push Button, Override **0B**
- Viton, Push Button, Override **VB**
- Buna, Screw, Override **0K**
- Viton, Screw, Override **VK**

BODIES

- Blank Without Body
- N** 1/4" BSP Ports (aluminum)
- N1** 3/8" BSP Ports (aluminum)
- S** #6 SAE Ports
- H** 1/4" BSP Ports (steel)
- H1** 3/8" BSP Ports (steel)

Note: Aluminum bodies only for use up to 250 bar

VOLTAGE (other voltages available on request)

- 12** 12 VDC
- 24** 24 VDC
- 26** 26 VDC

"P" TYPE "J" COIL TERMINATION

- JA** "J" Coil AMP Superseal - Integral
- JD** "J" Coil Deutsch - Integral DT04-2P
- JJ** "J" Coil AMP Jr. Time - Integral
- JL** "J" Coil Double Lead
- JH** "J" Coil DIN 43650 (Hirschmann)